



Hit



**Hit**

design Dante Bonuccelli

Sedia polifunzionale, che associa l'essenzialità del design alle prestazioni tecniche di livello superiore. Semplicità formale e innovative soluzioni costruttive definiscono una seduta dall'aspetto neutro ed elegante, che si integra perfettamente ad ambienti diversi, quali uffici, alberghi, abitazioni.

Caratterizzata da un'apparente rigidità strutturale, la sedia, nell'utilizzo, si trasforma in una comoda seduta, confortevole ed ergonomica, grazie a uno speciale telaio elastico inserito nella scocca in poliuretano. Proposta in un'ampia gamma di colori, Hit è disponibile sia nella versione sedia che poltroncina, entrambe impilabili.

A multi-purpose chair which associates essentiality of design with superior levels of technical performance. Formal simplicity and innovative constructional solutions qualify a chair with a neutral, elegant appearance which perfectly complements different environments such as offices, hotels and homes. Characterised by apparent structural rigidity, when in use it is transformed into a comfortable and ergonomic seat thanks to a special elastic frame placed inside the polyurethane shell. Available in a wide range of colours, Hit comes in both a chair version and a chair with arms version, both of which are stackable.



**Hit.** Lamm, 2006



flette in curve variabili ed ergonomiche grazie alla sua struttura interna composta da molle, profili e connessioni angolari metalliche che reagiscono elasticamente alle sollecitazioni della persona seduta.

hi-tech chair.  
all in integral  
polyurethane foam  
bends into variable ergonomic curves thanks to its complex internal structure which comprises leaf springs, sections and angular metal connections which react elastically to the sitter stresses.





Hit è una sedia dall'aspetto neutro ed elegante che si integra perfettamente in qualsiasi spazio collettivo. Disponibile nelle versioni sedia e poltroncina, entrambe impilabili.

Hit is a chair with a neutral and elegant appearance which perfectly complements any community area. Available with and without arms, both versions are stackable.





sedia e poltroncina,  
tata di un alto livello  
omfort che la rende  
ta anche agli spazi  
tesa, con possibilità  
binare il tavolino  
dinato.

with or without arms,  
res high levels of  
fort suitable also for  
ing areas, whit the  
sibility of a matching  
ll table.







## Disegni tecnici Technical drawings

### Sedia senza braccioli Chair without arms

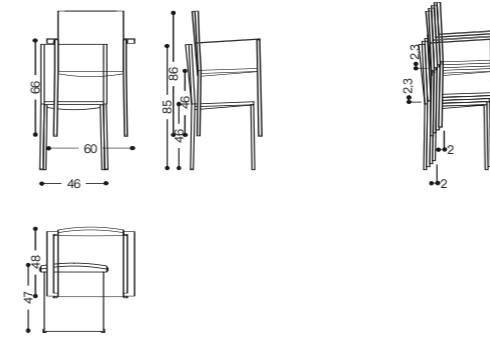

### Sedia con braccioli Chair with arms

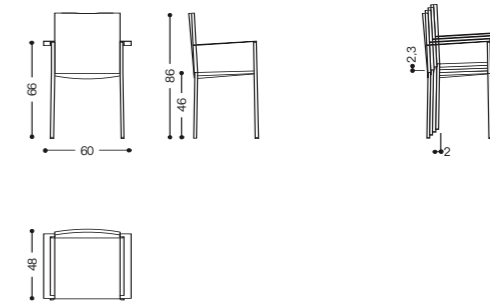

### Tavolino Table

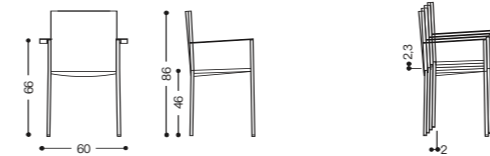
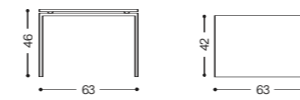

### Caratteristiche

Struttura in acciaio verniciato color alluminio o in acciaio inox con finitura lucida o satinata.  
 Scocca in poliuretano integrale con telaio strutturale interno composto da molle, profili e connessioni angolari metalliche. Disponibile anche con rivestimento in pelle.

### Features

Structure in aluminium coloured steel or in stainless steel with a polished or satin finish.  
 Shell in integral polyurethane foam with internal structural frame made up of leaf springs, sections and metal corner connections. Available also with leather covering.



Grigio scuro  
Dark grey

Bianco  
White

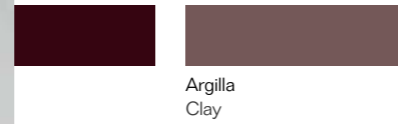

Argilla  
Clay

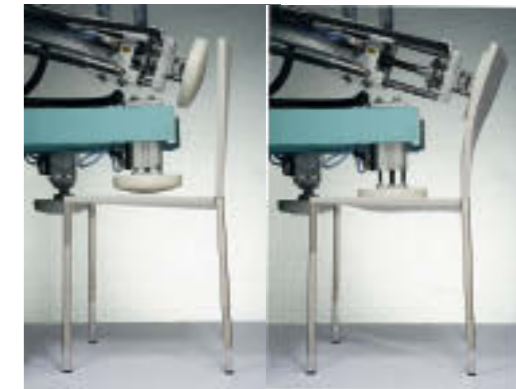



**Hit** design Dante Bonuccelli

**Lamm spa** via Verdi, 19/21 43017 San Secondo Parmense (Pr), Italy  
t. +39 0521.877511 fax +39 0521.877599 www.lamm.it info@lamm.it

